

GRADE 8 FASTENERS



- Minimum 150,000 psi Tensile Strength
- Meets Grade 8 Strength Specifications
- 30% Thicker Nuts for Easier Torquing and Less Wrench Slippage
- Alloy Steel Washers Provide Higher Strength Load Bearing Surface
- Cold Forged with Precision Rolled Threads
- Triple Heat Treated
- Zinc Dichromate Plating

CHROMATE GRADE 8 FASTENING SYSTEM MEETS ALL GRADE 8 SPECIFICATIONS.

Tested and proven to be one of the tough preventive maintenance fastening systems available. All components are manufactured to exacting specifications, triple heat treated for shock absorbing, fatigue resistant ductility and then zinc dichromate plated for corrosion resistance and durability. Always use the Chromate Grade 8 Fastening System when failure cannot be tolerated.



CHROMATE INDUSTRIAL CORP.

EXCEPTIONAL PRODUCTS, SERVICE AND INNOVATIVE SOLUTIONS

GRADE 8 CAP SCREWS

THE PREVENTIVE MAINTENANCE CAP SCREW

Medium carbon alloy steel, through hardened. U.S. made with U.S. steel and U.S. Labor. Minimum 150,000 psi tensile strength. Rockwell "C" hardness 33-39.

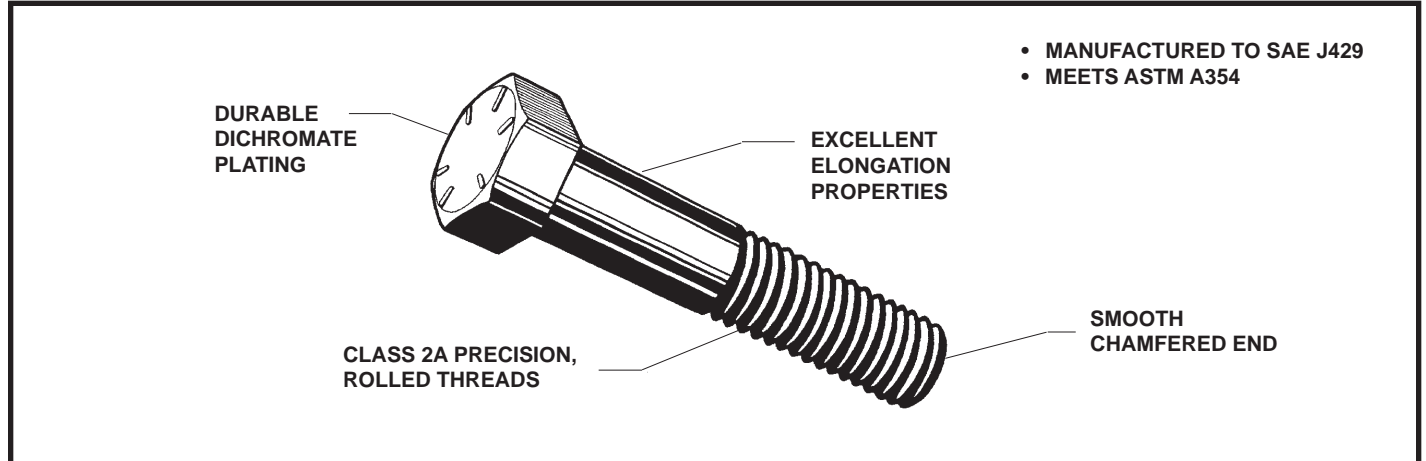

LENGTH	1/4 DIA.		5/16 DIA.		3/8 DIA.		7/16 DIA.	
	USS 20	SAE 28	USS 18	SAE 24	USS 16	SAE 24	USS 14	SAE 20
1/2	T 40700	T 41000	T 40726	T 41026	T 40752	T 41052	—	—
5/8	T 40701	T 41001	T 40727	T 41027	T 40753	T 41053	—	—
3/4	T 40702	T 41002	T 40728	T 41028	T 40754	T 41054	R 40782	R 41082
7/8	T 40703	T 41003	T 40729	T 41029	T 40755	T 41055	R 40783	R 41083
1	T 40704	T 41004	T 40730	T 41030	T 40756	T 41056	R 40784	R 41084
1-1/4	T 40706	T 41006	T 40732	T 41032	R 40758	R 41058	R 40785	R 41085
1-1/2	T 40707	T 41007	T 40733	T 41033	R 40759	R 41059	R 40786	R 41086
1-3/4	T 40708	T 41008	T 40734	T 41034	R 40760	R 41060	R 40787	R 41087
2	T 40709	T 41009	T 40735	R 41035	R 40761	R 41061	R 40788	N 41088
2-1/4	R 40710	T 41010	R 40736	R 41036	R 40762	R 41062	N 40789	N 41089
2-1/2	R 40711	T 41011	R 40737	R 41037	R 40763	R 41063	N 40790	N 41090
2-3/4	R 40712	R 41012	R 40738	R 41038	R 40764	R 41064	N 40791	N 41091
3	R 40713	R 41013	R 40739	R 41039	R 40765	R 41065	N 40792	N 41092
3-1/4	R 40714	R 41014	R 40740	R 41040	N 40766	N 41066	N 40793	N 41093
3-1/2	R 40715	R 41015	R 40741	N 41041	N 40767	N 41067	N 40794	N 41094
3-3/4	R 40716	R 41016	N 40742	N 41042	N 40768	N 41068	N 40795	N 41095
4	R 40717	N 41017	N 40743	N 41043	N 40769	N 41069	N 40796	I 41096
4-1/4	—	—	—	—	I 40770	I 41070	—	—
4-1/2	N 40718	N 41018	N 40744	N 41044	I 40771	I 41071	I 40797	I 41097
4-3/4	—	—	—	—	I 40772	I 41072	—	—
5	N 40719	I 41019	N 40745	I 41045	I 40773	I 41073	I 40798	I 41098
5-1/4	—	—	—	—	I 40774	I 41074	—	—
5-1/2	N 40720	I 41020	I 40746	I 41046	I 40775	I 41075	I 40799	I 41099
5-3/4	—	—	—	—	I 40776	I 41076	—	—
6	I 40721	I 41021	I 40747	I 41047	I 40777	I 41077	I 40800	I 41100
6-1/2	I 40722	I 41022	I 40748	I 41048	I 40778	I 41078	E 40801	E 41101
7	I 40723	I 41023	I 40749	I 41049	E 40779	E 41079	E 40802	E 41102
7-1/2	I 40724	I 41024	E 40750	E 41050	E 40780	E 41080	E 40803	E 41103
8	I 40725	I 41025	E 40751	E 41051	E 40781	E 41081	E 40804	E 41104

NOTE: NUMBERS IN ITALIC ARE NON-STOCK ITEMS. PLEASE ALLOW 2-3 WEEKS FOR DELIVERY.

GRADE 8 CAP SCREWS (Cont'd)

LENGTH	1/2 DIA.		9/16 DIA.		5/8 DIA.		3/4 DIA.	
	USS 13	SAE 20	USS 12	SAE 18	USS 11	SAE 18	USS 10	SAE 16
3/4	R 40805	R 41105	-	-	-	-	-	-
7/8	R 40806	R 41106	-	-	-	-	-	-
1	R 40807	R 41107	N 40831	N 41131	N 40852	I 41152	I 40879	I 41179
1-1/4	R 40809	N 41109	N 40832	N 41132	N 40853	I 41153	I 40880	I 41180
1-1/2	R 40810	N 41110	N 40833	N 41133	N 40854	I 41154	I 40881	I 41181
1-3/4	N 40811	N 41111	N 40834	N 41134	N 40855	I 41155	I 40882	I 41182
2	N 40812	N 41112	I 40835	I 41135	N 40856	I 41156	I 40883	I 41183
2-1/4	N 40813	N 41113	I 40836	I 41136	I 40857	I 41157	I 40884	E 41184
2-1/2	N 40814	N 41114	I 40837	I 41137	I 40858	I 41158	I 40885	E 41185
2-3/4	N 40815	N 41115	I 40838	I 41138	I 40859	I 41159	I 40886	E 41186
3	N 40816	N 41116	I 40839	I 41139	I 40860	I 41160	I 40887	E 41187
3-1/4	N 40817	N 41117	I 40840	I 41140	I 40861	I 41161	E 40888	E 41188
3-1/2	N 40818	N 41118	I 40841	I 41141	I 40862	I 41162	E 40889	E 41189
3-3/4	N 40819	I 41119	I 40842	I 41142	I 40863	I 41163	E 40890	E 41190
4	I 40820	I 41120	I 40843	I 41143	I 40864	I 41164	E 40891	E 41191
4-1/4	I 40821	I 41121	-	-	I 40865	I 41165	E 40892	-
4-1/2	I 40822	I 41122	I 40844	I 41144	I 40866	I 41166	E 40893	E 41193
4-3/4	I 40823	I 41123	-	-	I 40867	I 41167	-	-
5	I 40824	I 41124	I 40845	I 41145	I 40868	I 41168	E 40894	E 41194
5-1/2	I 40825	I 41125	I 40846	I 41146	E 40869	I 41169	E 40895	E 41195
6	I 40826	I 41126	E 40847	E 41147	E 40870	E 41170	E 40896	E 41196
6-1/2	E 40827	E 41127	E 40848	E 41148	E 40871	E 41171	E 40897	B 41197
7	E 40828	E 41128	E 40849	E 41149	E 40872	E 41172	B 40898	B 41198
7-1/2	E 40829	E 41129	E 40850	E 41150	E 40873	E 41173	B 40899	B 41199
8	E 40830	E 41130	B 40851	B 41151	E 40874	E 41174	B 40900	B 41200
8-1/2	-	-	-	-	E 40875	B 41175	B 40901	B 41201
9	-	-	-	-	B 40876	B 41176	B 40902	B 41202
9-1/2	-	-	-	-	B 40877	B 41177	B 40903	B 41203
10	-	-	-	-	B 40878	B 41178	B 40904	B 41204
LENGTH	7/8 DIA		1 DIA.		1-1/8 DIA.		1-1/4 DIA.	
	USS 9	SAE 14	USS 8	SAE 14	USS 7	SAE 12	USS 7	SAE 12
1-1/2	E 40905	E 41205	E 40929	E 41229	-	-	-	-
1-3/4	E 40906	E 41206	E 40930	E 41230	-	-	-	-
2	E 40907	E 41207	E 40931	E 41231	B 40953	B 41253	B 40974	B 41274
2-1/4	E 40908	E 41208	E 40932	E 41232	B 40954	B 41254	B 40975	B 41275
2-1/2	E 40909	E 41209	E 40933	E 41233	B 40955	B 41255	B 40976	B 41276
2-3/4	E 40910	E 41210	E 40934	E 41234	B 40956	B 41256	B 40977	B 41277
3	E 40911	E 41211	E 40935	B 41235	B 40957	B 41257	B 40978	B 41278
3-1/4	E 40912	E 41212	E 40936	B 41236	B 40958	B 41258	B 40979	B 41279
3-1/2	E 40913	E 41213	E 40937	B 41237	B 40959	B 41259	B 40980	B 41280
3-3/4	E 40914	E 41214	B 40938	B 41238	B 40960	B 41260	B 40981	B 41281
4	E 40915	E 41215	B 40939	B 41239	B 40961	B 41261	B 40982	B 41282
4-1/4	B 40916	B 41216	B 40940	B 41240	-	-	-	-
4-1/2	E 40917	B 41217	B 40941	B 41241	B 40962	B 41262	A 40983	A 41283
5	E 40918	B 41218	B 40942	B 41242	B 40963	B 41263	A 40984	A 41284
5-1/2	E 40919	B 41219	B 40943	B 41243	B 40964	B 41264	A 40985	A 41285
6	B 40920	B 41220	B 40944	B 41244	B 40965	A 41265	A 40986	A 41286
6-1/2	B 40921	B 41221	B 40945	B 41245	A 40966	A 41266	A 40987	A 41287
7	B 40922	B 41222	B 40946	B 41246	A 40967	A 41267	A 40988	A 41288
7-1/2	B 40923	B 41223	B 40947	B 41247	A 40968	A 41268	A 40989	A 41289
8	B 40924	B 41224	B 40948	A 41248	A 40969	A 41269	A 40990	A 41290
8-1/2	B 40925	A 41225	A 40949	A 41249	A 40970	A 41270	A 40991	A 41291
9	B 40926	A 41226	A 40950	A 41250	A 40971	A 41271	A 40992	A 41292
9-1/2	B 40927	A 41227	A 40951	A 41251	A 40972	A 41272	A 40993	A 41293
10	B 40928	A 41228	A 40952	A 41252	A 40973	A 41273	A 40994	A 41294

NOTE: NUMBERS IN ITALIC ARE NON-STOCK ITEMS. PLEASE ALLOW 2-3 WEEKS FOR DELIVERY.

GRADE 8 HEX NUTS

FINISHED THICK HEX NUTS

- USE WITH GRADE 8 AND ALLOY 200 CAP SCREWS FOR BALANCED ASSEMBLY
- EXCEEDS GRADE 8 SPECIFICATIONS BY 20%
- TRIPLE HEAT TREATED
- 30% THICKER FOR GREATER HOLDING/WRENCHING POWER
- 180,000 PSI MINIMUM TENSILE STRENGTH
- DICHROMATE PLATING AND WAXED

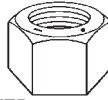

SIZE	TPI		WAF	HGT	USS	SAE
	USS	SAE				
T 1/4	20	28	7/16	9/32	4700	3700
T 5/16	18	24	1/2	21/64	4705	3705
T 3/8	16	24	9/16	13/32	4710	3710
R 7/16	14	20	11/16	29/64	4715	3715
R 1/2	13	20	3/4	9/16	4720	3720
N 9/16	12	18	7/8	39/64	4725	3725
N 5/8	11	18	15/16	23/32	4730	3730
L 3/4	10	16	1-1/8	13/16	4735	3735
I 7/8	9	14	1-5/16	27/32	4740	3740
E 1	8	14	1-1/2	1	4745	3745
B 1-1/8	7	12	1-11/16	1-3/16	4746	-
B 1-1/4	7	12	1-7/8	1-1/4	4747	3747
B 1-1/2	6	12	2-1/4	1-1/2	4748	-

GRADE 8 FINISHED NUTS

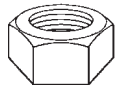

- MEETS GRADE 8 SPECIFICATIONS
- TRIPLE HEAT TREATED
- DICHROMATE PLATING



SIZE	TPI		WAF	HGT	USS	SAE
	USS	SAE				
T 1/4	20	28	7/16	7/32	8926	8905
T 5/16	18	24	1/2	17/64	8927	8906
T 3/8	16	24	9/16	21/64	8928	8907
R 7/16	14	20	11/16	3/8	8929	8908
R 1/2	13	20	3/4	7/16	8930	8909
R 9/16	12	18	7/8	31/64	8931	8910
R 5/8	11	18	15/16	35/64	8932	8911
N 3/4	10	16	1-1/8	41/64	8933	8912
I 7/8	9	14	1-5/16	3/4	8934	8913
I 1	8	14	1-1/2	55/64	8935	8914
I 1-1/8	7	12	1-11/16	31/32	13571	4771
I 1-1/4	7	12	1-7/8	1-1/16	13572	4772
I 1-3/8	6	12	2-1/16	1-11/64	13573	4773
I 1-1/2	6	12	2-1/4	1-9/32	13574	4774

PREVAILING TORQUE TAPER LOCK NUTS

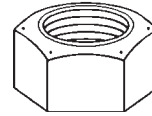

- USE WITH GRADE 8 AND ALLOY 200 CAP SCREWS
- GRADE C SPECIFICATIONS
- TRIPLE HEAT TREATED
- SUPERIOR VIBRATION AND SHOCK RESISTANCE
- 150,000 PSI
- CLEAR PLATING ZINC



SIZE	TPI		WAF	HGT	USS	SAE
	USS	SAE				
T 1/4	20	28	7/16	1/4	6800	5800
T 5/16	18	24	1/2	19/64	6805	5805
T 3/8	16	24	9/16	3/8	6810	5810
R 7/16	14	20	11/16	27/64	6815	5815
R 1/2	13	20	3/4	1/2	6820	5820
N 9/16	12	18	7/8	35/64	6825	5825
N 5/8	11	18	15/16	41/64	6830	5830
L 3/4	10	16	1-1/8	47/64	6835	5835
I 7/8	9	14	1-5/16	27/32	6840	5840
E 1	8	14	1-1/2	15/16	6845	5845
B 1-1/8	7	12	1-11/16	1-3/16	6846	5846
B 1-1/4	7	12	1-7/8	1-9/32	6847	5847
B 1-3/8	6	12	2-1/16	1-13/32	6842	-
B 1-1/2	6	12	2-1/4	1-17/32	6848	-

USS 2H HEAVY HEX NUTS

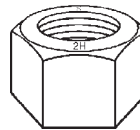

- EXTRA WIDTH FOR OVERSIZE WRENCHING
- MEETS ASTM 194-2H
- ANSI/ASME B18.2.1 1981
- PLAIN FINISH

SIZE	TPI USS	WAF	HGT	USS
R 3/8	16	11/16	23/64	4840
R 1/2	13	7/8	31/64	4850
N 5/8	11	1-1/16	39/64	4855
L 3/4	10	1-1/4	47/64	4860
I 7/8	9	1-7/16	55/64	4865
I 1	8	1-5/8	63/64	4870
B 1-1/4	7	2	1-7/32	4878
B 1-3/8	7	2-3/16	1-11/32	4882
B 1-1/2	6	2-3/8	1-15/32	4885

GRADE 8 ZINC YELLOW NYLON HEX NUTS

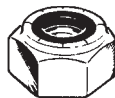

- SPECIAL PRIME STEEL
- ONE-PIECE NYLON INSERT FOR POSITIVE 360° LOCKING
- REUSABLE
- DICHROMATE PROTECTIVE PLATING



SIZE	TPI		WAF	HGT	USS	SAE	SIZE	TPI		WAF	HGT	USS	SAE
	USS	SAE						USS	SAE				
T 1/4	20	28	7/16	7/32	22020	22021	L 9/16	12	18	7/8	31/64	22030	22031
T 5/16	18	24	1/2	17/64	22022	22023	L 5/8	11	18	15/16	35/64	22032	22033
T 3/8	16	24	9/16	21/64	22024	22025	I 3/4	10	16	1-1/8	41/64	22034	22035
R 7/16	14	20	11/16	3/8	22026	22027	E 7/8	9	14	1-5/16	3/4	22036	22037
N 1/2	13	20	3/4	7/16	22028	22029	B 1	8	14	1-1/2	55/64	22038	22039

GRADE 8 ALLOY WASHERS

DESIGNED FOR HIGH STRENGTH LOAD BEARING APPLICATIONS

Grade 8 washers provide superior performance for all critical applications.

USS WIDE BAND FLAT WASHERS

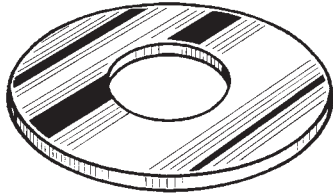

- DIMENSIONS ARE TO ANSI SPECIFICATIONS
- FABRICATED FROM QUALITY MEDIUM CARBON STEEL
- RC 38-45

- TRIPLE HEAT TREATED
- USS DIMENSIONS
- SMOOTH BEARING SURFACE
- DICHROMATE PLATING

	SIZE	I.D.	O.D.	PART
T	1/4	5/16	3/4	8000
T	5/16	3/8	7/8	8001
T	3/8	7/16	1	8002
T	7/16	1/2	1-1/4	8003
T	1/2	9/16	1-3/8	8004
R	9/16	5/8	1-1/2	8005
R	5/8	11/16	1-3/4	8006
N	3/4	13/16	2	8007
N	7/8	15/16	2-1/4	8008
N	1"	1-1/16	2-1/2	8009
I	1-1/8	1-1/4	2-3/4	8010
I	1-1/4	1-3/8	3	8011
I	1-3/8	1-1/2	3-1/4	8027
E	1-1/2	1-5/8	3-1/2	8012

SAE NARROW BAND FLAT WASHERS

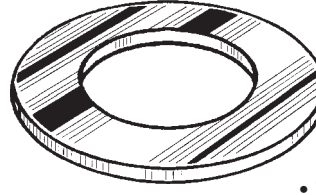

- DIMENSIONS ARE TO ANSI SPECIFICATIONS
- FABRICATED FROM QUALITY MEDIUM CARBON STEEL
- RC 38-45

- TRIPLE HEAT TREATED
- SAE DIMENSIONS
- SMOOTH BEARING SURFACE
- DICHROMATE PLATING

	SIZE	I.D.	O.D.	PART
T	1/4	9/32	5/8	9000
T	5/16	11/32	11/16	9001
T	3/8	13/32	13/16	9002
T	7/16	15/32	59/64	9003
T	1/2	17/32	1-1/16	9004
R	9/16	19/32	1-3/16	9005
R	5/8	11/16	1-5/16	9006
N	3/4	13/16	1-15/32	9007
N	7/8	15/16	1-3/4	9008
N	1"	1-1/8	2	9009
I	1-1/8	1-1/4	2-1/4	9010
I	1-1/4	1-3/8	2-1/2	9011
I	1-3/8	1-1/2	2-3/4	9013
I	1-1/2	1-5/8	3	9012
E	1-3/4	1-7/8	3-3/8	9014

STRUCTURAL FLAT WASHERS

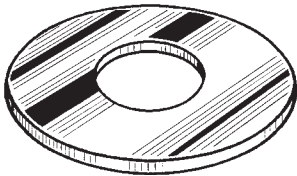

- HIGH STRENGTH MATERIAL
- FOR USE WITH A325 STRUCTURAL BOLTS
- PLAIN FINISH

SIZE	PART	SIZE	PART
1/2	T 1124	1-1/8	N 1130
5/8	R 1126	1-1/4	N 1131
3/4	R 1127	1-3/4	N 1133
7/8	N 1128	2	E 1134
1	N 1129	-	-

LOCK WASHERS

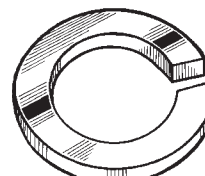

- TRIPLE HEAT TREATED
- RETAINS STRENGTH UNDER HIGH LOAD CONDITIONS
- MECHANICAL DICHROMATE PLATING TO AVOID HYDROGEN EMBRITTLEMENT
- RC 38-46

SIZE	PART	SIZE	PART
1/4	U 6300	3/4	R 6335
5/16	U 6305	7/8	R 6340
3/8	U 6310	1	N 6345
7/16	T 6315	1-1/8	L 6350
1/2	T 6320	1-1/4	I 6355
9/16	T 6325	1-1/2	I 6360
5/8	R 6330		

Vi-LOCK WASHERS

THE MOST RELIABLE VIBRATION-RESISTANT LOCKING DEVICE AVAILABLE

Meets military specification – MSN-5310-01-051-4149. Special Chromate protective plating eliminates rust and corrosion.

THE MORE THEY VIBRATE — THE TIGHTER THEY LOCK

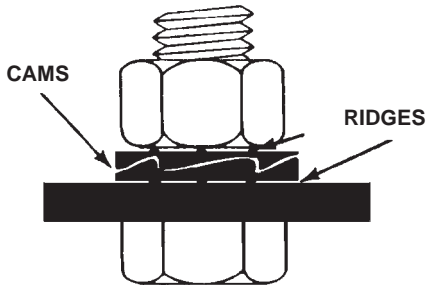

The Vi-LOC principle calls for two washer-shaped pieces that have inclined cams on one side and a series of ridges on the other. When the inclined cams are mated and set-up as shown in the diagram, one washer seizes to the joint material and the other washer to the nut or capscrew.

When the bolt contracts, the inclined planes of the cams cause the nut or capscrew to rotate back to its original position. This creates a fastening system that is vibration proof and meets military specifications.

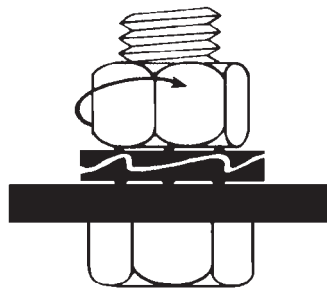

The Vi-LOC fastening system may be loosened by exerting approximately 50% more torque than required for tightening.

When a bolt elongates due to vibration or shock, the nut or capscrew starts to rotate loose. The Vi-LOC system prevents this since the cam rise angle is greater than the lead angle of the thread. As one piece of the Vi-LOC attempts to rotate with the nut or capscrew, the preload is actually increased, forcing the assembly back to a tight fitting unit.



VI-LOCK WASHERS

- USE ONLY IN PAIRS
- SELF-MATING
- RIDGES ON OUTSIDE

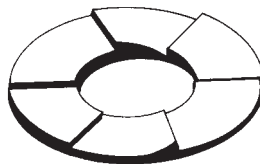

- RESISTS:
- VIBRATION
 - LOST HOLDING POWER
 - SLIPPAGE
 - WEAR
 - EQUIPMENT BREAKDOWN

SIZE	INSIDE DIAMETER	OUTSIDE DIAMETER		PART
3/16 (5mm)	.203"	.401"	U	6100
1/4 (6mm)	.262"	.495"	U	6101
5/16 (8mm)	.326"	.628"	U	6102
3/8 (10mm)	.409"	.705"	T	6103
7/16 (11mm)	.450"	.880"	T	6104
1/2 (12mm)	.510"	1.005"	R	6105
9/16 (14mm)	.572"	1.128"	O	6106
5/8 (16mm)	.651"	1.247"	O	6107
3/4 (20mm)	.820"	1.381"	O	6110
7/8 (22mm)	.883"	1.470"	L	6111
1" (25mm)	1.015"	1.626"	L	6112

GRADE 8 UNI-FIT™ FLAT WASHERS

TIGHTER TOLERANCE WITH INCREASED BEARING SURFACE

11

A superior strength flat washer combining the closer inside diameter tolerance of an SAE washer with the greater load bearing surface of a USS washer.

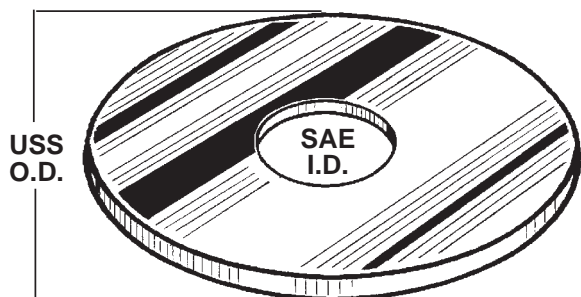

- **THICKER, WIDER PATTERN**
IMPROVED STRENGTH AND INCREASED BEARING SURFACE FOR MORE UNIFORM TORQUE TENSION PERFORMANCE.
- **MARKED WITH CIC LOGO AND SIZE**
FOR TRACEABILITY AND EASY IDENTIFICATION.
- **FEWER SIZES NEEDED**
LOWERS INVENTORY COSTS.
- **YELLOW DICHROMATE MECHANICAL PLATING**
ASSURES SUPERIOR RESISTANCE TO RUST AND CORROSION FOR LONGER LIFE.
- **MANUFACTURED FROM HIGH STRENGTH, HEAT-TREATED ALLOY STEEL**
ASSURES HIGHEST CLAMPING LOAD WITHOUT DISHING, BENDING OR GALLING.

SIZE	THICKNESS	ID	OD	PART	
1/4	.086	9/32	3/4	U	5400
5/16	.086	11/32	7/8	U	5401
3/8	.086	13/32	1	U	5402
7/16	.098	15/32	1-1/4	T	5403
1/2	.132	17/32	1-3/8	T	5404
5/8	.146	11/16	1-3/4	R	5406
3/4	.146	13/16	2	O	5407

GRADE 8 USS ALLOY FASTENERS

80 HOLE USS BIN ASSORTMENT



This assortment is filled and labeled with 70 of the fastest moving fastener sizes for all your maintenance needs... In 2 all steel 40 hole bins!

P/N 7835

ASSORTMENT CONTAINS

- 49 Sizes Alloy Cap Screws 1/4" thru 3/4" Diameter
- 7 Sizes Alloy Finished Thick Hex Nuts 1/4" thru 3/4" Diameter
- 7 Sizes Alloy Uni-Fit™ Flat Washers 1/4" thru 3/4" Diameter
- 7 Sizes Alloy Lock Washers 1/4" thru 3/4" Diameter
- 2 Steel 40 Hole Bin - P/N 7903 33-3/4" W x 22-1/2" H x 12" D

See Bin Assortment layout on reverse side for complete details.

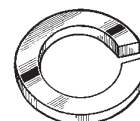
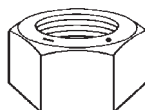
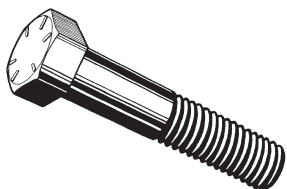

FOR MORE INFORMATION ON OUR PRODUCTS OR SYSTEMS, CALL 1-800-BUY-BOLT

GRADE 8 USS ALLOY FASTENER ASSORTMENT

P/N 7835 — USS SIZES — 70 ITEMS / 80 HOLES

1/4-20 FINISHED HEX NUT 8926	5/16-18 FINISHED HEX NUT 8927	3/8-16 FINISHED HEX NUT 8928	7/16-14 FINISHED HEX NUT 8929	1/2-13 FINISHED HEX NUT 8930	EXPANSION	5/8-11 FINISHED HEX NUT 8932	3/4-10 FINISHED HEX NUT 8933
1/4 UNI-FIT™ FLAT WASHER 5400	5/16 UNI-FIT™ FLAT WASHER 5401	3/8 UNI-FIT™ FLAT WASHER 5402	7/16 UNI-FIT™ FLAT WASHER 5403	1/2 UNI-FIT™ FLAT WASHER 5404	EXPANSION	5/8 UNI-FIT™ FLAT WASHER 5406	3/4 UNI-FIT™ FLAT WASHER 5407
1/4 LOCK WASHER 6300	5/16 LOCK WASHER 6305	3/8 LOCK WASHER 6310	7/16 LOCK WASHER 6315	1/2 LOCK WASHER 6320	EXPANSION	5/8 LOCK WASHER 6330	3/4 LOCK WASHER 6335
1/4 x 1/2 CAP SCREW 40700	5/16 x 1/2 CAP SCREW 40726	3/8 x 3/4 CAP SCREW 40754	7/16 x 1 CAP SCREW 40784	1/2 x 1 CAP SCREW 40807	EXPANSION	5/8 x 1 CAP SCREW 40852	3/4 x 1-1/2 CAP SCREW 40881
1/4 x 3/4 CAP SCREW 40702	5/16 x 3/4 CAP SCREW 40728	3/8 x 1 CAP SCREW 40756	7/16 x 1-1/2 CAP SCREW 40786	1/2 x 1-1/2 CAP SCREW 40810	EXPANSION	5/8 x 1-1/2 CAP SCREW 40854	3/4 x 2 CAP SCREW 40883
1/4 x 1 CAP SCREW 40704	5/16 x 1 CAP SCREW 40730	3/8 x 1-1/4 CAP SCREW 40758	7/16 x 2 CAP SCREW 40788	1/2 x 2 CAP SCREW 40812	EXPANSION	5/8 x 2 CAP SCREW 40856	3/4 x 2-1/2 CAP SCREW 40885
1/4 x 1-1/2 CAP SCREW 40707	5/16 x 1-1/2 CAP SCREW 40733	3/8 x 1-1/2 CAP SCREW 40759	7/16 x 2-1/2 CAP SCREW 40790	1/2 x 2-1/2 CAP SCREW 40814	EXPANSION	5/8 x 2-1/2 CAP SCREW 40858	3/4 x 3 CAP SCREW 40887
1/4 x 2 CAP SCREW 40709	5/16 x 2 CAP SCREW 40735	3/8 x 2 CAP SCREW 40761	7/16 x 3 CAP SCREW 40792	1/2 x 3 CAP SCREW 40816	EXPANSION	5/8 x 3 CAP SCREW 40860	3/4 x 3-1/2 CAP SCREW 40889
1/4 x 2-1/2 CAP SCREW 40711	5/16 x 2-1/2 CAP SCREW 40737	3/8 x 2-1/2 CAP SCREW 40763	7/16 x 3-1/2 CAP SCREW 40794	1/2 x 3-1/2 CAP SCREW 40818	EXPANSION	5/8 x 3-1/2 CAP SCREW 40862	3/4 x 4 CAP SCREW 40891
1/4 x 3 CAP SCREW 40713	5/16 x 3 CAP SCREW 40739	3/8 x 3 CAP SCREW 40765	7/16 x 4 CAP SCREW 40796	1/2 x 4 CAP SCREW 40820	EXPANSION	5/8 x 4 CAP SCREW 40864	3/4 x 5 CAP SCREW 40894

GRADE 8 SAE ALLOY FASTENERS

80 HOLE SAE BIN ASSORTMENT



This assortment is filled and labeled with 70 of the fastest moving fastener sizes for all your maintenance needs... In 2 all steel 40 hole bins!

P/N 7836

ASSORTMENT CONTAINS

- 49 Sizes Alloy Cap Screws 1/4" thru 3/4" Diameter
- 7 Sizes Alloy Finished Thick Hex Nuts 1/4" thru 3/4" Diameter
- 7 Sizes Alloy Uni-Fit™ Flat Washers 1/4" thru 3/4" Diameter
- 7 Sizes Alloy Lock Washers 1/4" thru 3/4" Diameter
- 2 Steel 40 Hole Bin - P/N 7903 33-3/4" W x 22-1/2" H x 12" D

See Bin Assortment layout on reverse side for complete details.

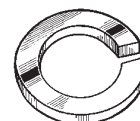
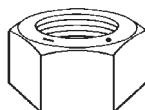
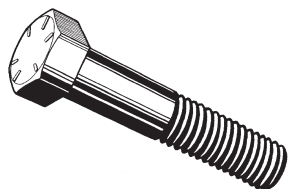

FOR MORE INFORMATION ON OUR PRODUCTS OR SYSTEMS, CALL 1-800-BUY-BOLT

GRADE 8 SAE ALLOY FASTENER ASSORTMENT

P/N 7836 — SAE SIZES — 70 ITEMS / 80 HOLES

1/4-28 FINISHED HEX NUT 8905	5/16-24 FINISHED HEX NUT 8906	3/8-24 FINISHED HEX NUT 8907	7/16-20 FINISHED HEX NUT 8908	1/2-20 FINISHED HEX NUT 8909	EXPANSION	5/8-18 FINISHED HEX NUT 8911	3/4-16 FINISHED HEX NUT 8912
1/4 UNI-FIT™ FLAT WASHER 5400	5/16 UNI-FIT™ FLAT WASHER 5401	3/8 UNI-FIT™ FLAT WASHER 5402	7/16 UNI-FIT™ FLAT WASHER 5403	1/2 UNI-FIT™ FLAT WASHER 5404	EXPANSION	5/8 UNI-FIT™ FLAT WASHER 5406	3/4 UNI-FIT™ FLAT WASHER 5407
1/4 LOCK WASHER 6300	5/16 LOCK WASHER 6305	3/8 LOCK WASHER 6310	7/16 LOCK WASHER 6315	1/2 LOCK WASHER 6320	EXPANSION	5/8 LOCK WASHER 6330	3/4 LOCK WASHER 6335
1/4 x 1/2 CAP SCREW 41000	5/16 x 1/2 CAP SCREW 41026	3/8 x 3/4 CAP SCREW 41054	7/16 x 1 CAP SCREW 41084	1/2 x 1 CAP SCREW 41107	EXPANSION	5/8 x 1 CAP SCREW 41152	3/4 x 1-1/2 CAP SCREW 41181
1/4 x 3/4 CAP SCREW 41002	5/16 x 3/4 CAP SCREW 41028	3/8 x 1 CAP SCREW 41056	7/16 x 1-1/2 CAP SCREW 41086	1/2 x 1-1/2 CAP SCREW 41110	EXPANSION	5/8 x 1-1/2 CAP SCREW 41154	3/4 x 2 CAP SCREW 41183
1/4 x 1 CAP SCREW 41004	5/16 x 1 CAP SCREW 41030	3/8 x 1-1/4 CAP SCREW 41058	7/16 x 2 CAP SCREW 41088	1/2 x 2 CAP SCREW 41112	EXPANSION	5/8 x 2 CAP SCREW 41156	3/4 x 2-1/2 CAP SCREW 41185
1/4 x 1-1/2 CAP SCREW 41007	5/16 x 1-1/2 CAP SCREW 41033	3/8 x 1-1/2 CAP SCREW 41059	7/16 x 2-1/2 CAP SCREW 41090	1/2 x 2-1/2 CAP SCREW 41114	EXPANSION	5/8 x 2-1/2 CAP SCREW 41158	3/4 x 3 CAP SCREW 41187
1/4 x 2 CAP SCREW 41009	5/16 x 2 CAP SCREW 41035	3/8 x 2 CAP SCREW 41061	7/16 x 3 CAP SCREW 41092	1/2 x 3 CAP SCREW 41116	EXPANSION	5/8 x 3 CAP SCREW 41160	3/4 x 3-1/2 CAP SCREW 41189
1/4 x 2-1/2 CAP SCREW 41011	5/16 x 2-1/2 CAP SCREW 41037	3/8 x 2-1/2 CAP SCREW 41063	7/16 x 3-1/2 CAP SCREW 41094	1/2 x 3-1/2 CAP SCREW 41118	EXPANSION	5/8 x 3-1/2 CAP SCREW 41162	3/4 x 4 CAP SCREW 41191
1/4 x 3 CAP SCREW 41013	5/16 x 3 CAP SCREW 41039	3/8 x 3 CAP SCREW 41065	7/16 x 4 CAP SCREW 41096	1/2 x 4 CAP SCREW 41120	EXPANSION	5/8 x 4 CAP SCREW 41164	3/4 x 5 CAP SCREW 41194

GRADE 8 USS ALLOY FASTENERS

40 HOLE USS BIN ASSORTMENT

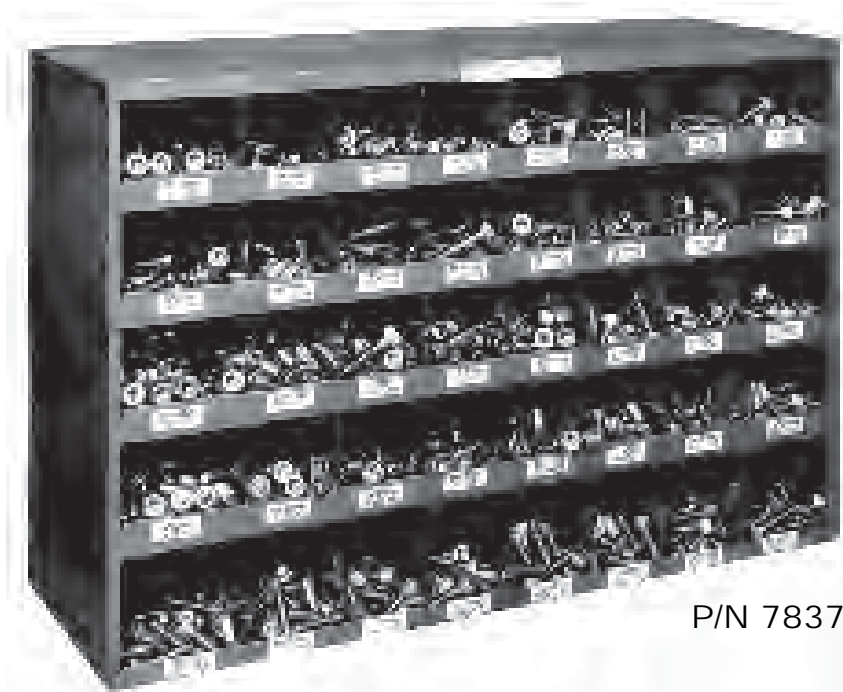

This assortment is filled and labeled with 40 of the fastest moving fastener sizes for all your maintenance needs!

ASSORTMENT CONTAINS

- 25 Sizes Alloy Cap Screws 1/4" thru 1/2" Diameter
- 5 Sizes Alloy Finished Thick Hex Nuts 1/4" thru 1/2" Diameter
- 5 Sizes Alloy Flat Washers 1/4" thru 1/2" Diameter
- 5 Sizes Alloy Lock Washers 1/4" thru 1/2" Diameter
- 1 Steel 40 Hole Bin - P/N 7903 33-3/4" W x 22-1/2" H x 12" D

See Bin Assortment layout on reverse side for complete details.

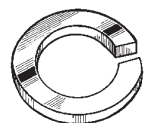
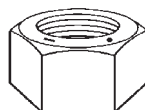
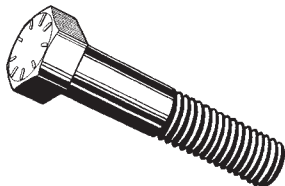

FOR MORE INFORMATION ON OUR PRODUCTS OR SYSTEMS, CALL 1-800-BUY-BOLT

GRADE 8 USS ALLOY FASTENER ASSORTMENT

P/N 7837 — USS SIZES — 40 ITEMS / 40 HOLES

1/4-20 FINISHED HEX NUT 8926	1/4 UNI-FIT™ FLAT WASHER 5400	1/4 LOCK WASHER 6300	1/4 x 1/2 CAP SCREW 40700	1/4 x 3/4 CAP SCREW 40702	1/4 x 1 CAP SCREW 40704	1/4 x 1-1/2 CAP SCREW 40707	1/4 x 2 CAP SCREW 40709
5/16-18 FINISHED HEX NUT 8927	5/16 UNI-FIT™ FLAT WASHER 5401	5/16 LOCK WASHER 6305	5/16 x 1/2 CAP SCREW 40726	5/16 x 3/4 CAP SCREW 40728	5/16 x 1 CAP SCREW 40730	5/16 x 1-1/2 CAP SCREW 40733	5/16 x 2 CAP SCREW 40735
3/8-16 FINISHED HEX NUT 8928	3/8 UNI-FIT™ FLAT WASHER 5402	3/8 LOCK WASHER 6310	3/8 x 3/4 CAP SCREW 40754	3/8 x 1 CAP SCREW 40756	3/8 x 1-1/4 CAP SCREW 40758	3/8 x 1-1/2 CAP SCREW 40759	3/8 x 2 CAP SCREW 40761
7/16-14 FINISHED HEX NUT 8929	7/16 UNI-FIT™ FLAT WASHER 5403	7/16 LOCK WASHER 6315	7/16 x 1 CAP SCREW 40784	7/16 x 1-1/2 CAP SCREW 40786	7/16 x 2 CAP SCREW 40788	7/16 x 2-1/2 CAP SCREW 40790	7/16 x 3 CAP SCREW 40792
1/2-13 FINISHED HEX NUT 8930	1/2 UNI-FIT™ FLAT WASHER 5404	1/2 LOCK WASHER 6320	1/2 x 1 CAP SCREW 40807	1/2 x 1-1/2 CAP SCREW 40810	1/2 x 2 CAP SCREW 40812	1/2 x 2-1/2 CAP SCREW 40814	1/2 x 3 CAP SCREW 40816

40 HOLE SAE BIN ASSORTMENT

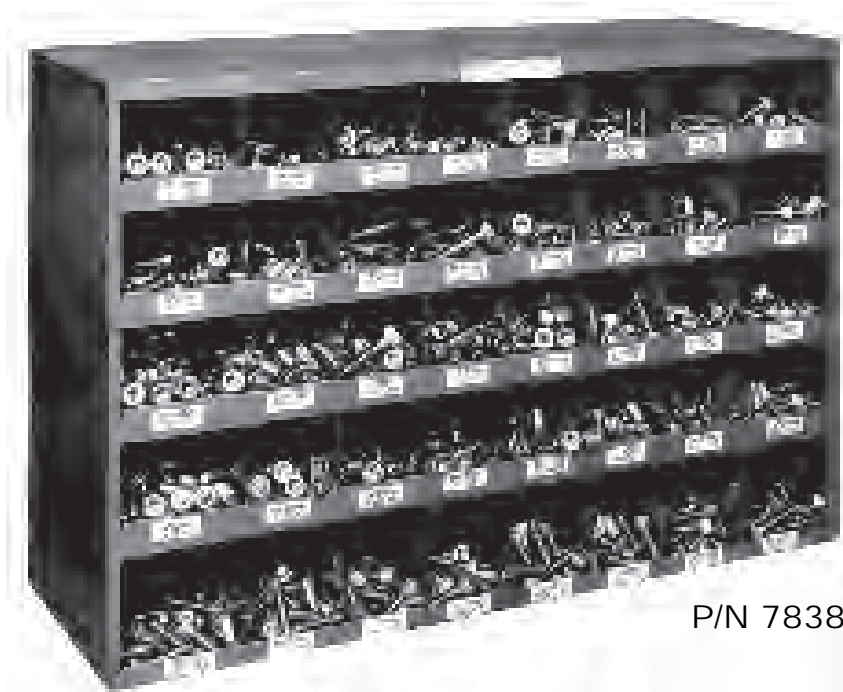

This assortment is filled and labeled with 40 of the fastest moving fastener sizes for all your maintenance needs!

ASSORTMENT CONTAINS

- 25 Sizes Alloy Cap Screws 1/4" thru 1/2" Diameter
- 5 Sizes Alloy Finished Thick Hex Nuts 1/4" thru 1/2" Diameter
- 5 Sizes Alloy Flat Washers 1/4" thru 1/2" Diameter
- 5 Sizes Alloy Lock Washers 1/4" thru 1/2" Diameter
- 1 Steel 40 Hole Bin - P/N 7903 33-3/4" W x 22-1/2" H x 12" D

See Bin Assortment layout on reverse side for complete details.

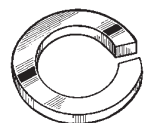
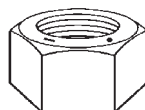
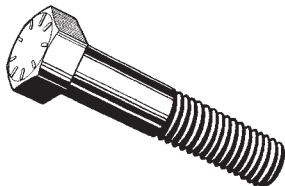

FOR MORE INFORMATION ON OUR PRODUCTS OR SYSTEMS, CALL 1-800-BUY-BOLT

GRADE 8 SAE ALLOY FASTENER ASSORTMENT

P/N 7838 — SAE SIZES — 40 ITEMS / 40 HOLES

1/4-28 FINISHED HEX NUT 8905	1/4 UNI-FIT™ FLAT WASHER 5400	1/4 LOCK WASHER 6300	1/4 x 1/2 CAP SCREW 41000	1/4 x 3/4 CAP SCREW 41002	1/4 x 1 CAP SCREW 41004	1/4 x 1-1/2 CAP SCREW 41007	1/4 x 2 CAP SCREW 41009
5/16-24 FINISHED HEX NUT 8906	5/16 UNI-FIT™ FLAT WASHER 5401	5/16 LOCK WASHER 6305	5/16 x 1/2 CAP SCREW 41026	5/16 x 3/4 CAP SCREW 41028	5/16 x 1 CAP SCREW 41030	5/16 x 1-1/2 CAP SCREW 41033	5/16 x 2 CAP SCREW 41035
3/8-24 FINISHED HEX NUT 8907	3/8 UNI-FIT™ FLAT WASHER 5402	3/8 LOCK WASHER 6310	3/8 x 3/4 CAP SCREW 41054	3/8 x 1 CAP SCREW 41056	3/8 x 1-1/4 CAP SCREW 41058	3/8 x 1-1/2 CAP SCREW 41059	3/8 x 2 CAP SCREW 41061
7/16-20 FINISHED HEX NUT 8908	7/16 UNI-FIT™ FLAT WASHER 5403	7/16 LOCK WASHER 6315	7/16 x 1 CAP SCREW 41084	7/16 x 1-1/2 CAP SCREW 41086	7/16 x 2 CAP SCREW 41088	7/16 x 2-1/2 CAP SCREW 41090	7/16 x 3 CAP SCREW 41092
1/2-20 FINISHED HEX NUT 8909	1/2 UNI-FIT™ FLAT WASHER 5404	1/2 LOCK WASHER 6320	1/2 x 1 CAP SCREW 41107	1/2 x 1-1/2 CAP SCREW 41110	1/2 x 2 CAP SCREW 41112	1/2 x 2-1/2 CAP SCREW 41114	1/2 x 3 CAP SCREW 41116

SERVICE MODULES

GRADE 8 USS ALLOY FASTENERS

EACH MODULE CONTAINS

Cap Screws

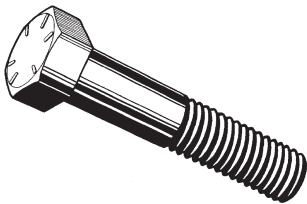

Flat Washers

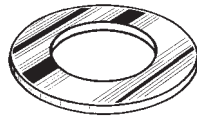

LockWashers

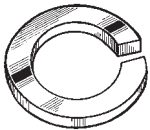

Hex Nuts

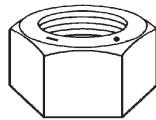

Our SERVICE MODULES make ordering fasteners fast and easy while saving you money!

Why order eight individual part numbers for a single diameter when you can use one.

One Service Module part number gives you five of the most popular cap screw lengths and the appropriate nuts, lock washers and flat washers.

-
- 1/4 Service Module P/N 914008
 - 5/16 Service Module P/N 956008
 - 3/8 Service Module P/N 938008
 - 7/16 Service Module P/N 976008
 - 1/2 Service Module P/N 912008
 - 5/8 Service Module P/N 958008
 - 3/4 Service Module P/N 934008

STORAGE BINS

Convenient and rugged. Made from heavy gauge steel with a durable baked enamel finish.



40 HOLE BIN
P/N 7903

BIN DIMENSIONS:
33-3/4" W x 12" D x 23-7/8" H

COMPARTMENT SIZE:
4" W x 11-7/8" D x 4-1/2" H

USE BASE: P/N 7909



24 HOLE BIN
P/N 7901

BIN DIMENSIONS:
33-3/4" W x 12" D x 23-7/8" H

COMPARTMENT SIZE:
5-3/8" W x 11-7/8" D x 5-1/2" H

USE BASE: P/N 7909

GRADE 8 USS ALLOY FASTNERS

1/4 SERVICE MODULE • P/N 914008

QTY.	DESCRIPTION	P/N
200	Lock Washer	6300
100	Flat Washer	5400
100	Hex Nut	8926
100	1/4-20 x 1/2 Gr 8 HHCS	40700
100	1/4-20 x 3/4 Gr 8 HHCS	40702
100	1/4-20 x 1 Gr 8 HHCS	40704
100	1/4-20 x 1-1/2 Gr 8 HHCS	40707
100	1/4-20 x 2 Gr 8 HHCS	40709

5/16 SERVICE MODULE • P/N 956008

QTY.	DESCRIPTION	P/N
200	Lock Washer	6305
100	Flat Washer	5401
100	Hex Nut	8927
100	5/16-18 x 1/2 Gr 8 HHCS	40726
100	5/16-18 x 3/4 Gr 8 HHCS	40728
100	5/16-18 x 1 Gr 8 HHCS	40730
100	5/16-18 x 1-1/2 Gr 8 HHCS	40733
100	5/16-18 x 2 Gr 8 HHCS	40735

3/8 SERVICE MODULE • P/N 938008

QTY.	DESCRIPTION	P/N
200	Lock Washer	6310
100	Flat Washer	5402
100	Hex Nut	8928
100	3/8-16 x 3/4 Gr 8 HHCS	40754
100	3/8-16 x 1 Gr 8 HHCS	40756
50	3/8-16 x 1-1/4 Gr 8 HHCS	40758
50	3/8-16 x 1-1/2 Gr 8 HHCS	40759
50	3/8-16 x 2 Gr 8 HHCS	40761

7/16 SERVICE MODULE • P/N 976008

QTY.	DESCRIPTION	P/N
100	Lock Washer	6315
50	Flat Washer	5403
50	Hex Nut	8929
50	7/16-14 x 1 Gr 8 HHCS	40784
50	7/16-14 x 1-1/2 Gr 8 HHCS	40786
50	7/16-14 x 2 Gr 8 HHCS	40788
25	7/16-14 x 2-1/2 Gr 8 HHCS	40790
25	7/16-14 x 3 Gr 8 HHCS	40792

1/2 SERVICE MODULE • P/N 912008

QTY.	DESCRIPTION	P/N
100	Lock Washer	6320
50	Flat Washer	5404
50	Hex Nut	8930
50	1/2-13 x 1 Gr 8 HHCS	40807
25	1/2-13 x 1-1/2 Gr 8 HHCS	40810
25	1/2-13 x 2 Gr 8 HHCS	40812
25	1/2-13 x 2-1/2 Gr 8 HHCS	40814
25	1/2-13 x 3 Gr 8 HHCS	40816

5/8 SERVICE MODULE • P/N 958008

QTY.	DESCRIPTION	P/N
50	Lock Washer	6330
50	Flat Washer	5406
25	Hex Nut	8932
20	5/8-11 x 1 Gr 8 HHCS	40852
20	5/8-11 x 1-1/2 Gr 8 HHCS	40854
20	5/8-11 x 2 Gr 8 HHCS	40856
10	5/8-11 x 2-1/2 Gr 8 HHCS	40858
10	5/8-11 x 3 Gr 8 HHCS	40860

3/4 SERVICE MODULE • P/N 934008

QTY.	DESCRIPTION	P/N
50	Lock Washer	6335
25	Flat Washer	5407
20	Hex Nut	8933
10	3/4-10 x 1-1/2 Gr 8 HHCS	40881
10	3/4-10 x 2 Gr 8 HHCS	40883
10	3/4-10 x 2-1/2 Gr 8 HHCS	40885
10	3/4-10 x 3 Gr 8 HHCS	40887
10	3/4-10 x 4 Gr 8 HHCS	40891